

- 1 Feed GROMMET-ARC through the 80mm (3.15") hole.

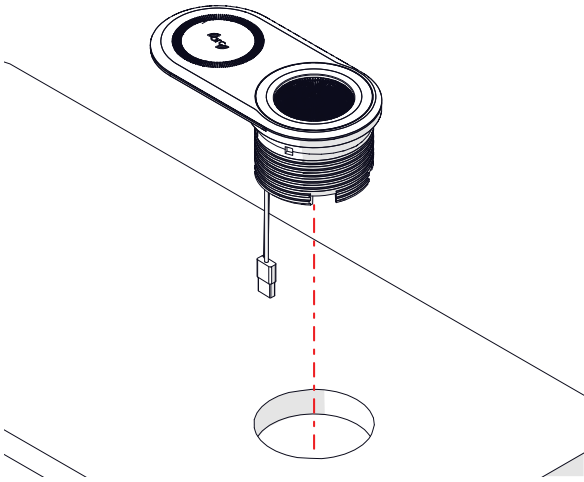

- 2 Check to ensure orientation of GROMMET-ARC is correct when tightening nut. Screw retaining nut until firmly in place.

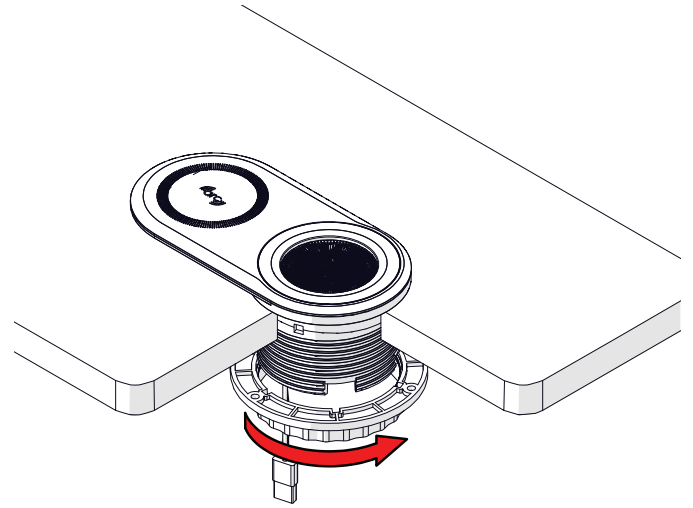

- 3
- 
- Screwing in the nut is optional.
- A technical line drawing showing the GROMMET-ARC component fully installed in the hole. A callout circle provides a magnified view of the retaining nut being screwed onto the base of the component. The text 'Screwing in the nut is optional.' is placed next to the callout.

