

Thick panel

1 Cutouts & screw positions

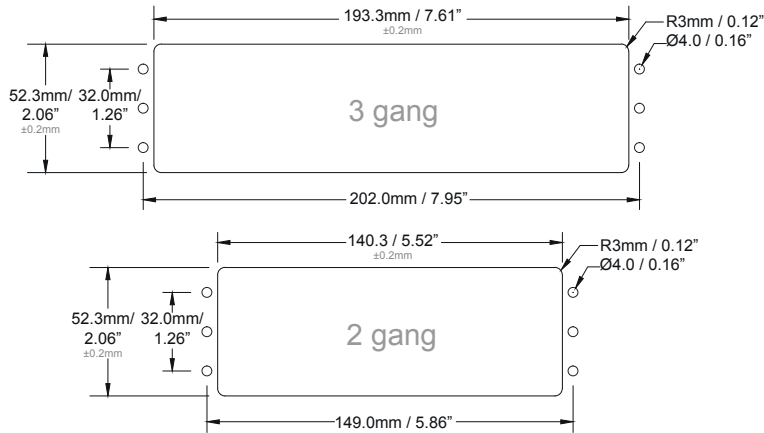

2 Remove frame

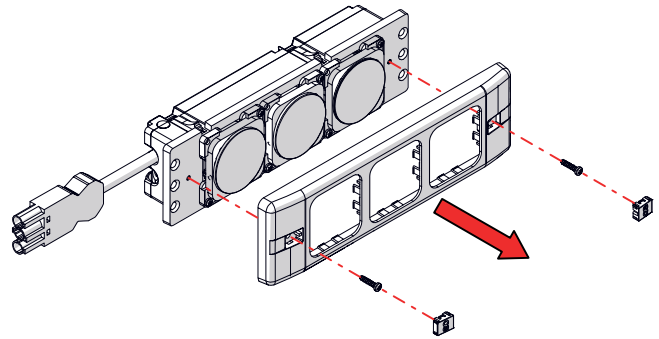

3

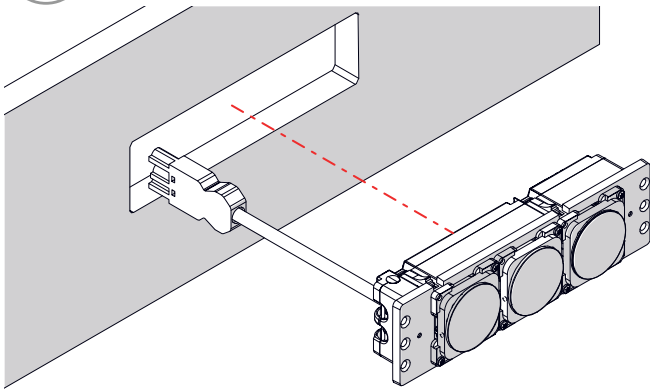

4 Screw PUMA in place

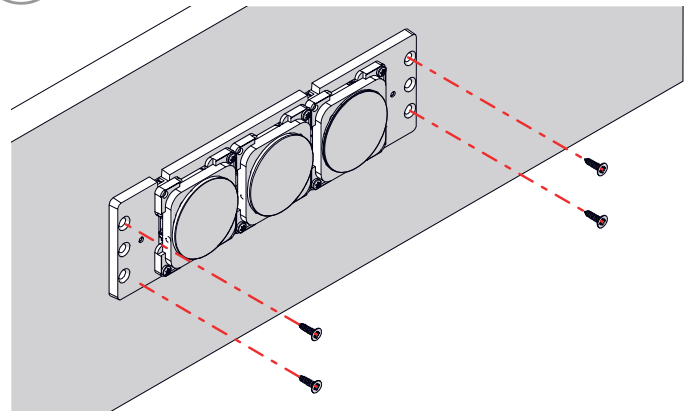

5 Fix frame to PUMA

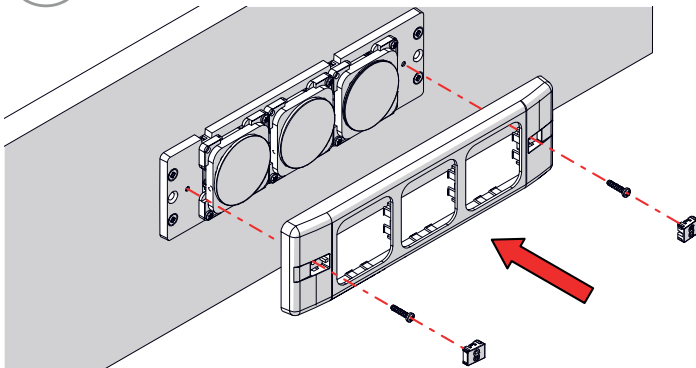

6

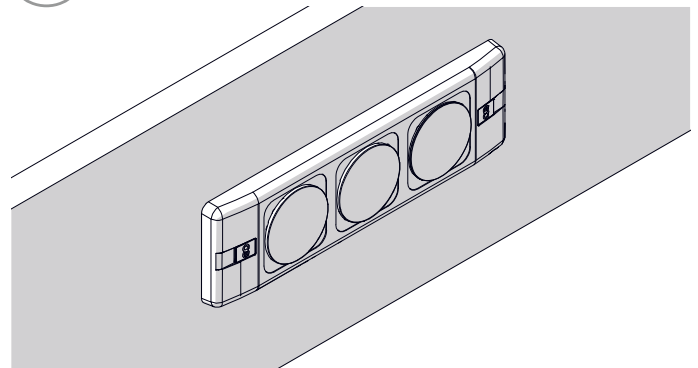

Thin panel

1 Cutouts & depth required

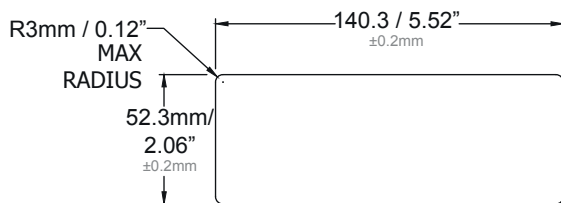
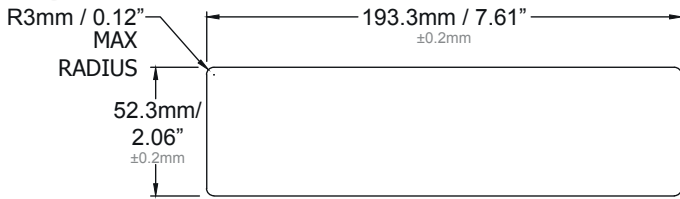

2 Max panel thickness 3mm / 0.12" (+/- 0.1mm / 0.004")

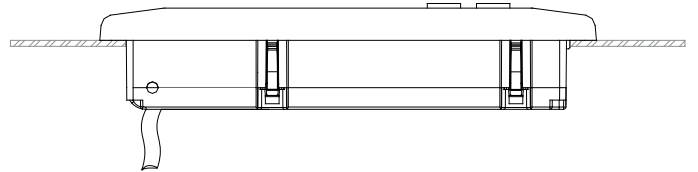

3

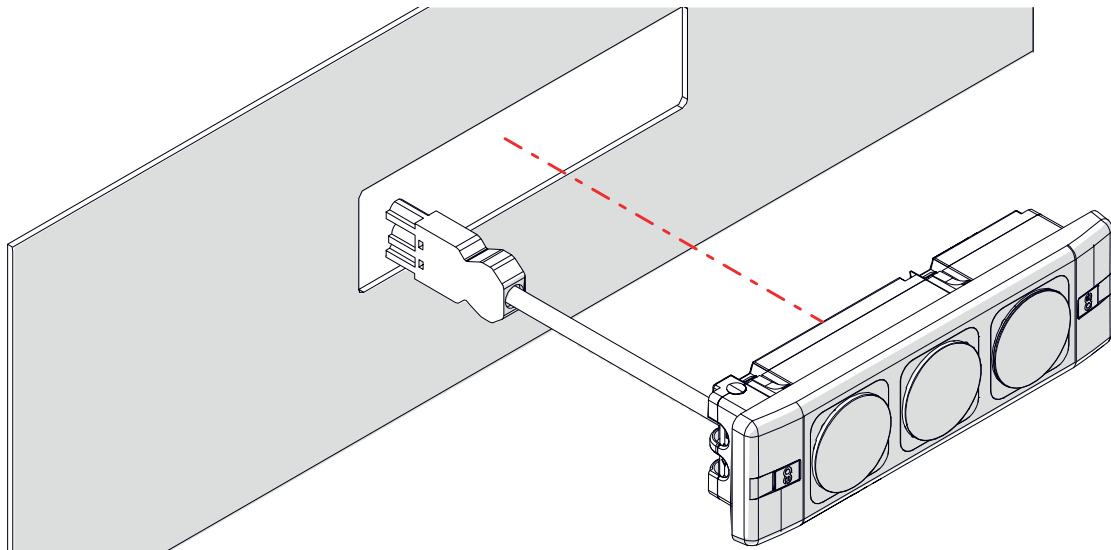

4

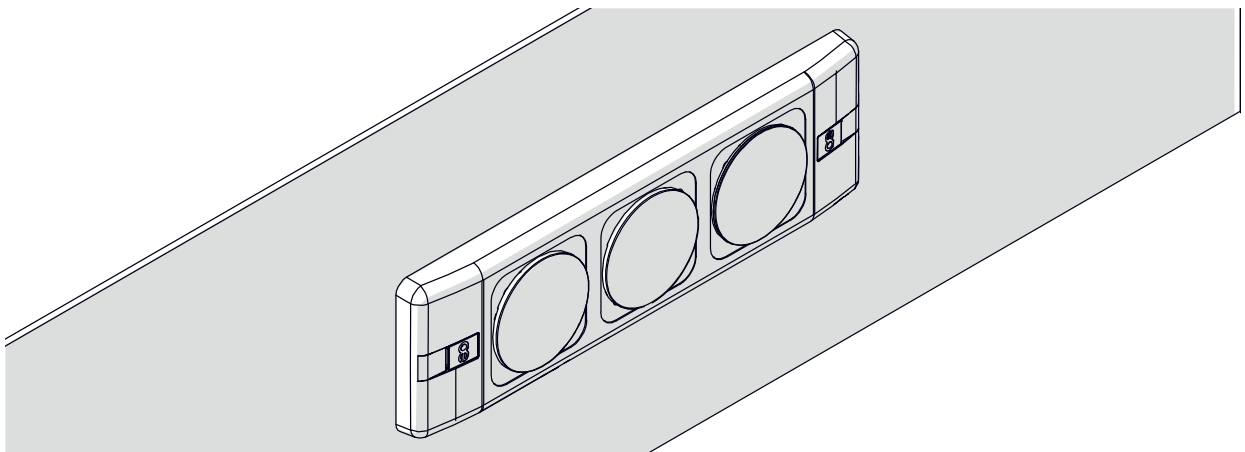

Flush mount

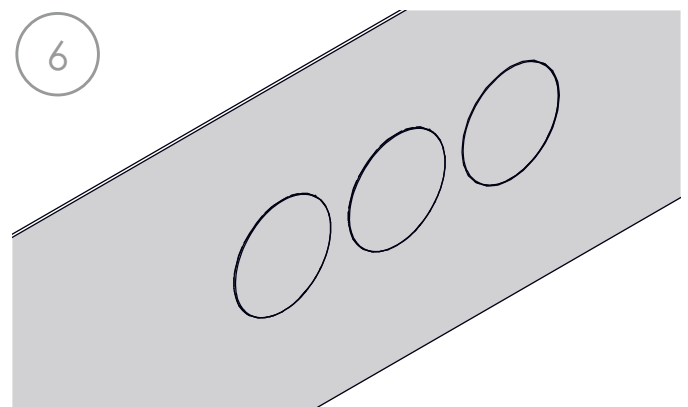
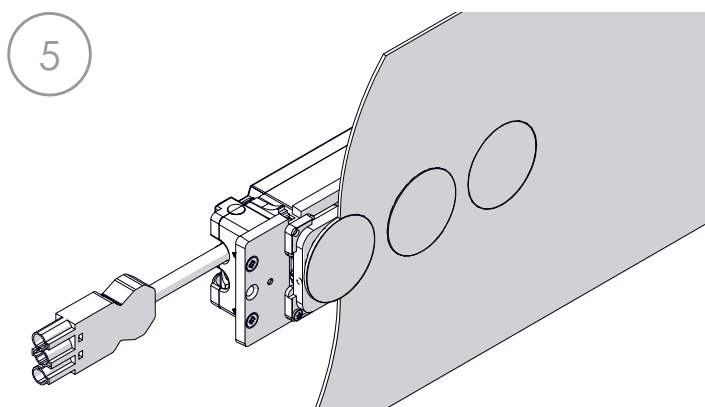
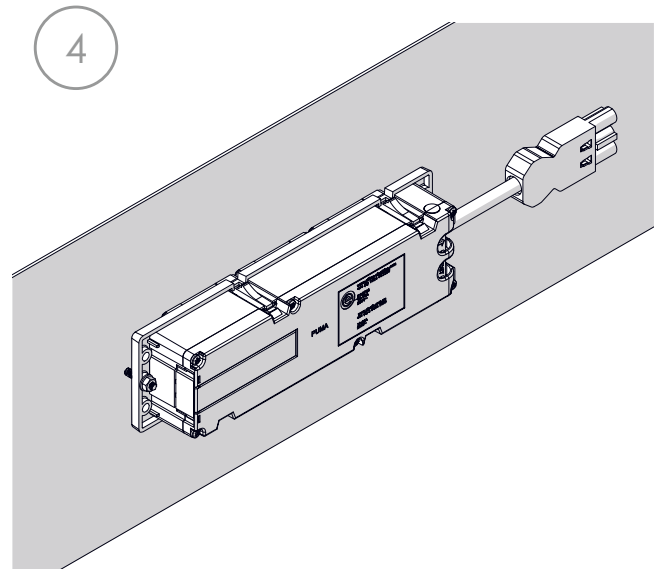
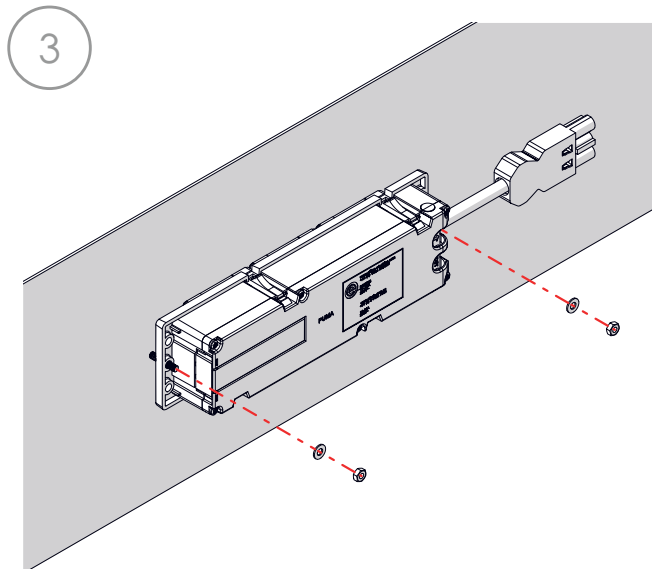
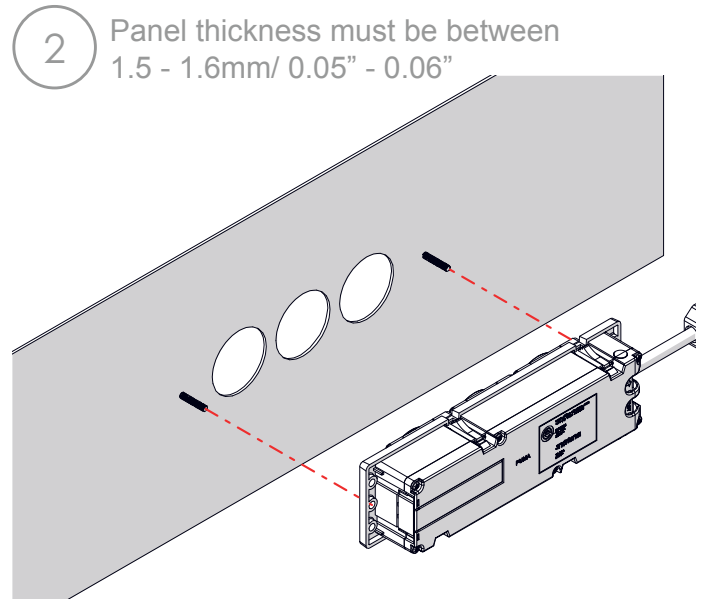
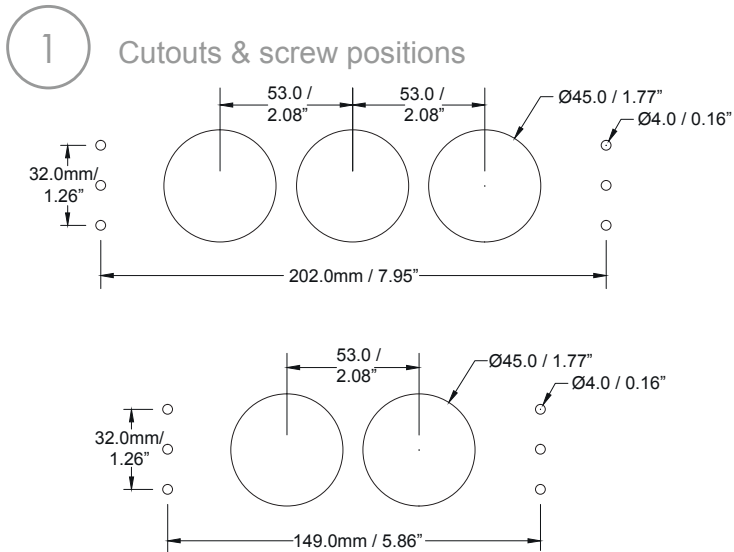

Shallow cavity

1 Cutouts & depth required

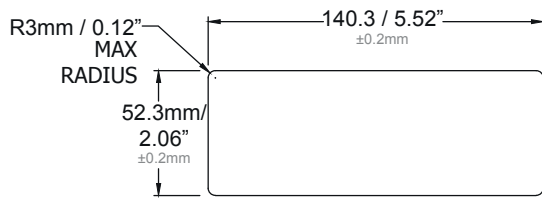
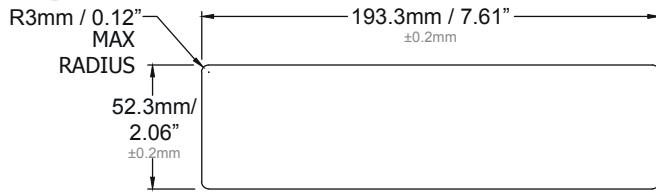

2 Slide in the right hand side

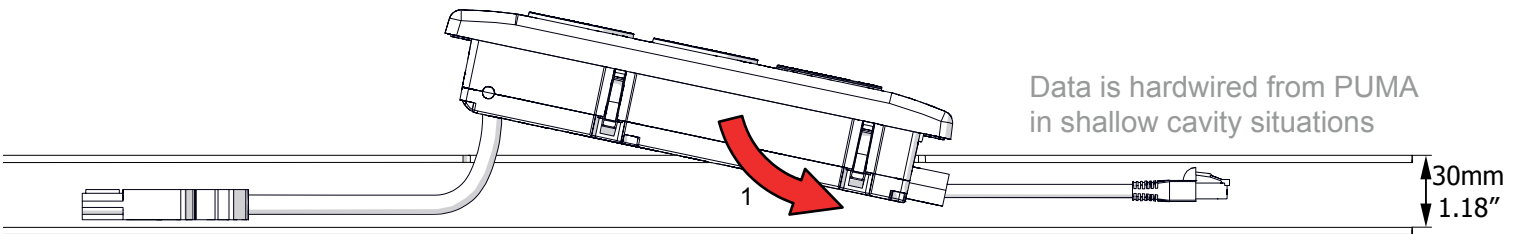

3 Press down to snap in place

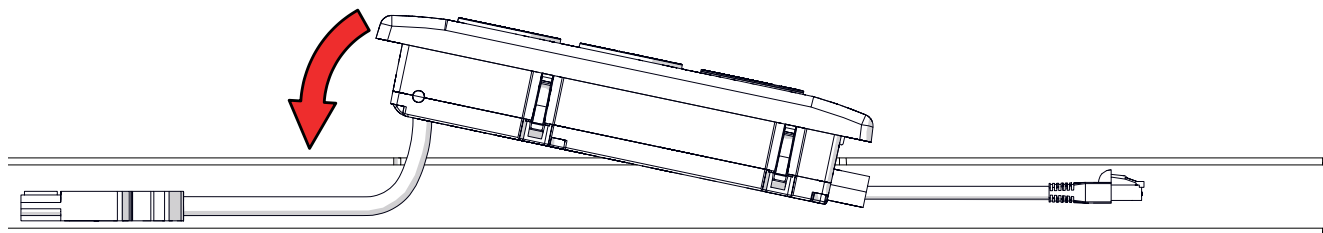

4

