

OE Head Office

www.oeelectronics.co.uk
+44 (0) 1924 367255
sales@oeelectronics.co.uk

OE GmbH

www.oeelectronics.de
+49 (0)2261 958 3001
info@oeelectronics.de

OE Inc

www.oeelectronics.com
+1 (844)-927-0600
sales@oeelectronics.com

10W Fast Wireless Charger 80mm Grommet Fit Installation Manual

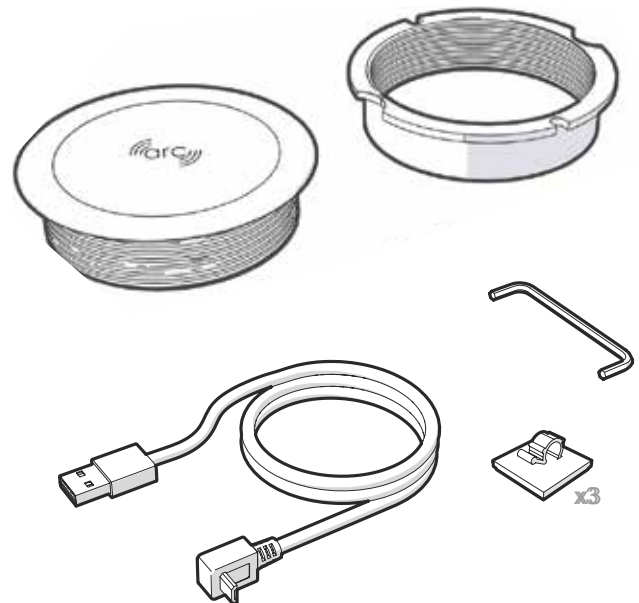

oeelsafe

www.oeelsafe.com.au
+61 2 9454 7500
sales@oeelsafe.com.au

Lose those annoying cables and
get charging with ARC80

Simply rest your wireless
compatible phone on our wireless
charger for a fast convenient
charge



(Although a phone case/wallet can be left on, we advise that cards and/or coins are not positioned between the phone and the charger)

Part Numbers

4251194	ARC80 - Black center with a black anodized aluminium rim
4251187	ARC80 - White center with a silver anodized aluminium rim
4251200	15W USB Power adapter (sold separately)

Specifications

Output power	10W Max (DC5V 1A / 9V 1.1A)
Input Power	15W Max (DC5V 2A / 9V 1.67A)
Standby Power	0.45W
Charging Z- Distance	0-0.3" (coil to coil)
Surface Cutout Size	3.15" (80mm)
Surface Thickness	0.08-1.38" (2-35mm) Reversible mounting collar for 0.08-0.71" (2-18mm) and 0.71-1.38" (18-35mm)
Certification	CE Qi Certified FCC Part 15
Housing Material	Anodised Aluminium
In the box	ARC80 wireless charger, Mounting tool & USB-A to Micro-USB cable (ARC80 can be powered up to 10W from a standard USB type-A outlet)

For surfaces 2-18mm (0.08 - 0.71") thick

1

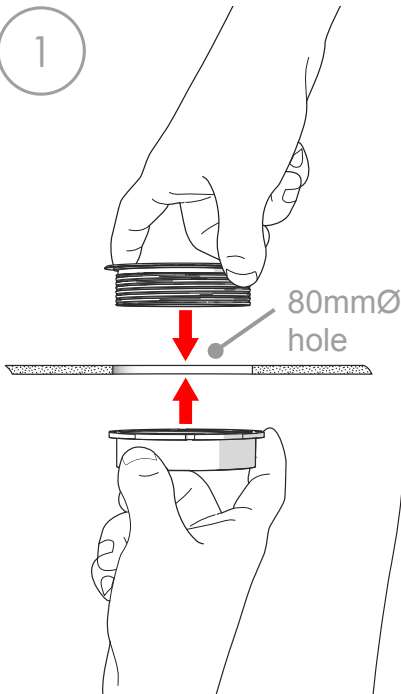

2



3

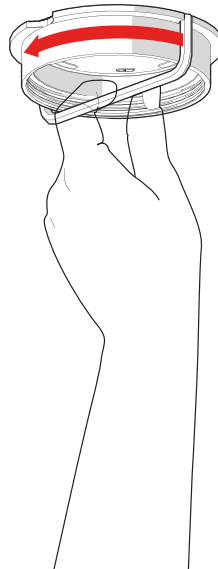

4

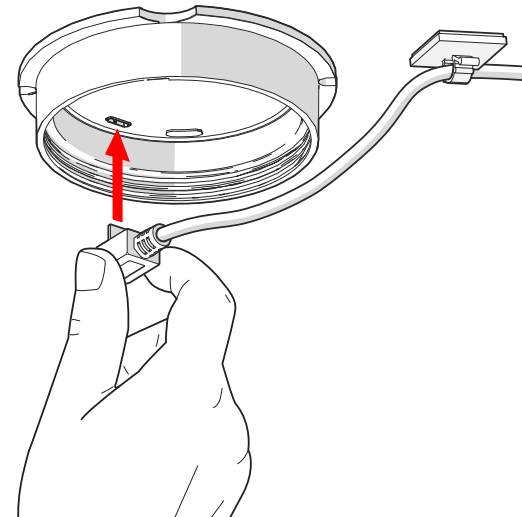

For surfaces 18-35mm (0.71 - 1.38") thick

1

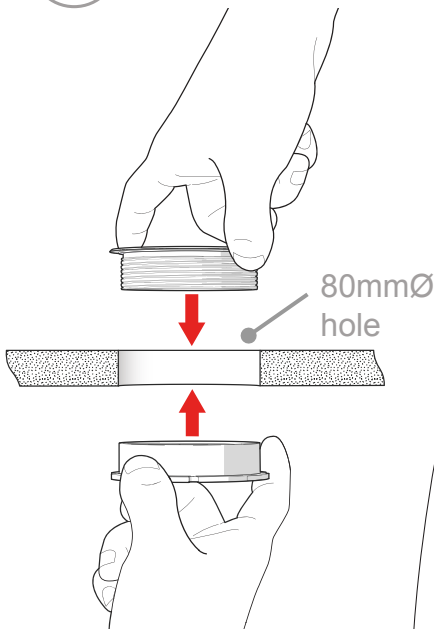

2



3

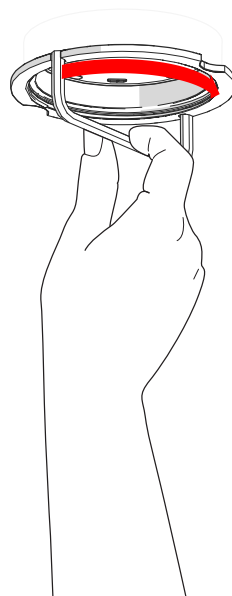

4

